

SOUTH OXFORDSHIRE

DESIGN GUIDE

TECHNICAL DOCUMENTS

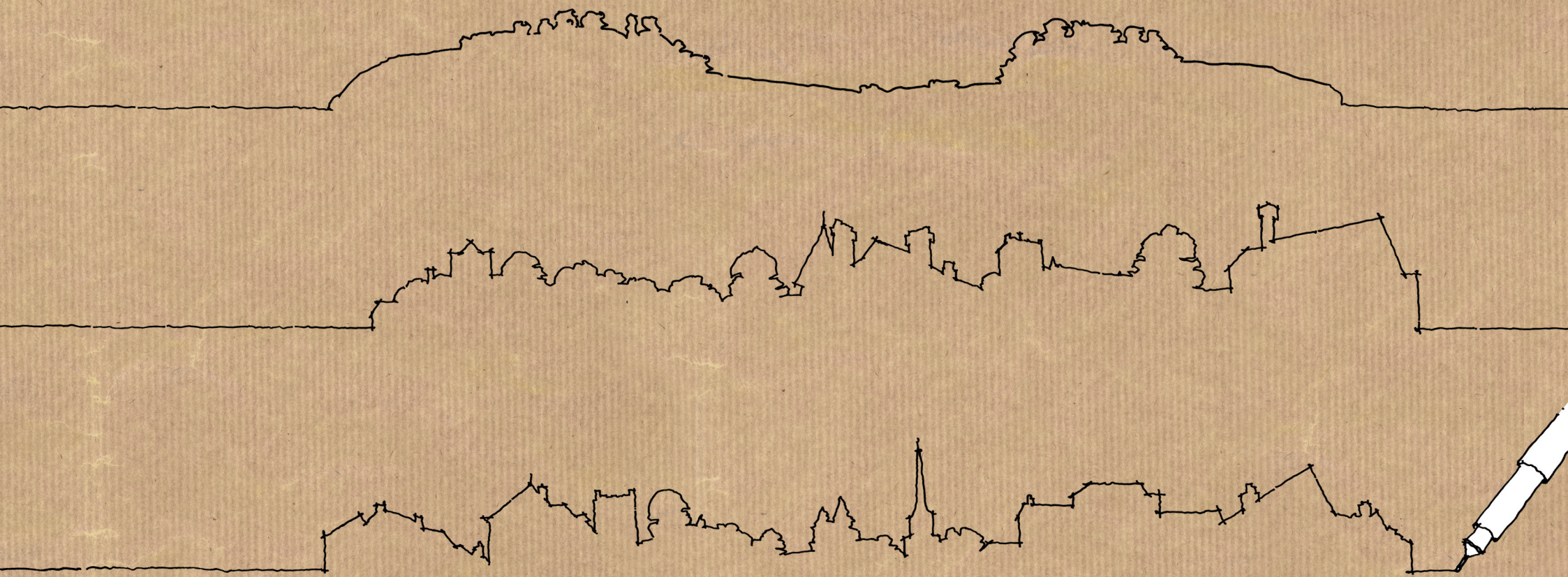

INTRODUCTION

The South Oxfordshire design guide is accompanied by a suite of technical documents focusing on disciplines such as landscape, biodiversity, trees, public art, sustainable energy, etc., all of which need to be taken into account at the outset of the design process alongside the principles set out in the Part 1 and 2 of the guide. The technical documents also focus on other types of development such as non-domestic buildings, apartments, householder extensions and outbuildings, building conversions, shopfronts and signage.

This document was prepared by the urban design officers and the specialists team at:



South Oxfordshire District Council
135 Eastern Avenue
Milton Park
Milton
OX14 4SB

T: 01235 540546
E: planning@southoxon.gov.uk
W: www.southoxon.gov.uk

In collaboration with:



Roberts Limbrick Architects
The Estates Office
25-26 Gold Tops
Newport
NP20 4PG

T: 03333 405500
E: mail@robertslimbrick.com
W: www.robertslimbrick.com

CONTENTS

PART 1	
What do we want to achieve? (under separate cover)	
WHAT DO WE WANT TO ACHIEVE?	6
<ul style="list-style-type: none"> - Purpose of the guide - We want to deliver high quality development - Why is this important? - Key design objectives - Urban design principles 	
HOW TO DO IT	10
<ul style="list-style-type: none"> - Structure of the guide - The steps to take - The design process - The design team - The council services - Who to consult - How to consult 	
THIS IS SOUTH OXFORDSHIRE	12
<ul style="list-style-type: none"> - Key facts - Character areas - Historic features, heritage and natural environment 	

PART 2	
The steps to take (under separate cover)	
1 LET'S GET DESIGNING	22
<ul style="list-style-type: none"> - Understanding the site's features and its setting - Developing a design rationale 	
2 THE NATURAL ENVIRONMENT	24
<ul style="list-style-type: none"> - Natural features and resources 	
3 MOVEMENT	26
<ul style="list-style-type: none"> - Creating a network of streets 	
4 DEVELOPMENT BLOCKS	28
<ul style="list-style-type: none"> - Density and uses 	
5 STREETS AS CIVILISED SPACES	30
<ul style="list-style-type: none"> - Creating definition and enclosure - Street design - Open space design - Street furniture, lighting and public art - Storage, servicing and utilities 	
6 PARKING	38
<ul style="list-style-type: none"> - Parking strategy and solutions 	
7 BUILDINGS AND PLOTS	40
<ul style="list-style-type: none"> - Form, character, scale and massing - Amenity spaces 	
8 ENSURING QUALITY	44
<ul style="list-style-type: none"> - Securing design quality - Maintenance and management 	
9 BRINGING IT TOGETHER	48
<ul style="list-style-type: none"> - High quality on every scale - Delivering a high quality development 	

PART 3	
Technical Documents	
1 LANDSCAPE STRUCTURE	4
2 TREES AND LANDSCAPING	8
3 BIODIVERSITY	12
4 SUSTAINABLE ENERGY	22
5 PUBLIC ART	26
6 HOUSEHOLDER EXTENSIONS AND OUTBUILDINGS	28
7 BUILDING CONVERSIONS	34
8 SHOPFRONTS AND SIGNAGE	36
9 NON-DOMESTIC BUILDINGS	40
10 APARTMENTS	44

UNDERSTANDING AND WORKING WITH THE EXISTING LANDSCAPE

GOAL: To make sure that a detailed understanding of the particular qualities and characteristics of the wider landscape has been taken into account at the outset of the design process and that the proposed development is designed so that it can integrate with and enhance the existing landscape and/or settlement.

The landscape of South Oxfordshire gets its unique identity from the natural setting and historical development. New development should respect, respond and enhance this unique **landscape character**. New development should share common characteristics with its locality and reinforce local identity as well as providing well-designed, accessible landscapes and public open spaces.

Designers often refer to green and blue infrastructure as key elements of landscape which will influence the proposal. **Green Infrastructure (GI)** is a planned and managed network of multifunctional green spaces which can provide a healthy and rich environment. These can include: allotments, gardens, including communal green spaces within housing areas, green corridors, brownfield and greenfield sites, urban parks and gardens, registered commons, village and town greens, children's play space, natural and semi-natural habitat for wildlife, playing fields, cemeteries, pocket parks, country parks, woodland, nature reserves, Sites of Special Scientific Interest and Scheduled Monuments. Blue infrastructure would include waterways and waterbodies, including flooded quarries.



An example of the landscape character found in the Vale Fringes in Ewelme



To inform your design:

Technical studies including (but not limited to) surveys on trees, topographical survey, etc.



To communicate your design:

- Prepare a Landscape Strategy that sets out how the existing landscape and biodiversity features on the site will be maintained and managed;
- Demonstrate how the features of a Sustainable Drainage Systems (SuDS), e.g. retaining ponds and swales, will be integrated into the landscape of the development.
- Undertake a landscape appraisal (see test your design section overleaf)



View north from Wittenham Clumps

Terms for Glossary:

Landscape character - The distinct and recognisable pattern of elements and features in the landscape that makes one landscape different from another.

Landscape appraisal - This is the consideration of the physical aspects of the site in order to identify key constraints and opportunities.

Landscape structure - This is the proposed landscape, incorporating existing landscape features and providing new ones to enhance and integrate the development.

Green infrastructure - This is a multifunctional landscape that incorporates the widest range of functions an open space can support to unlock the greatest number of benefits.

TEST YOUR DESIGN:

A **landscape character** assessment has been carried out which includes the following:

- 1.1 identifies and describes the character of the landscape in which the site is set by referring to existing landscape character assessments at the national, regional and district level including historic landscape character assessments, where available;
- 1.2 identifies the landscape features and historic development of the landscape setting that helps to form its essential character;
- 1.3 identifies the perceptual qualities that add to its character such as remoteness/busyness, darkness/lighting, quiet/noise;
- 1.4 describes how the existing site relates to and reflects this landscape setting;
- 1.5 identifies any important views to and from the site that are valuable to its sense of place;
- 1.6 identifies what landscape elements (views, topography, water, vegetation etc) should be retained and enhanced within any new development to ensure it integrates and enhances the landscape setting.

Meets criteria If not, reason for not meeting

Landscape appraisal

- 1.7 A landscape appraisal has been undertaken which identifies clearly on a plan the key constraints to any future development including topography, trees and hedgerows, views to and from the site, land use, water features, rights of way, historic features, etc.



A form of green infrastructure (allotments, Didcot)



Additional useful and interesting resources:

- National Landscape Character Area profiles (Natural England, 2014)
- SODC Landscape Characterisation Assessment (1998)
- Historic Landscape Character (Oxfordshire County Council, 2016)
- Guidelines for landscape and visual impact assessment (Landscape Institute, 3rd ed. 2013)
- Chilterns AONB Management Plan (2014-2019)
- Chilterns Buildings Design Guide and Supplementary Technical Notes (CCB, 2nd ed., 2010)
- North Wessex Downs Management Plan
- Design for play (Play England, 2008) and Public space lessons (Design Council/ CABE, 2008)
- An approach to Landscape Character Assessment (Natural England, 2014)



TEST YOUR DESIGN:

Ensure the landscape structure:

- Meets criteria If not, reason for not meeting
- 1.8 retains landscape features identified in the appraisal which are important now, in terms of contributing towards landscape character and setting, or will become important when the site is developed;
 - 1.9 incorporates these features into the new landscape structure as they will not only help integrate the new development but will provide instant 'maturity' as well as creating windbreaks, visual screening and shelter;
 - 1.10 incorporates the existing public rights of way within the new movement network to ensure connectivity;
 - 1.11 ensures all open spaces have an identified purpose and be of the size, location and form appropriate for that use;
 - 1.12 does not use planting as a divisive measure between new and existing development as it leads to isolated pockets of development and areas vulnerable to social misuse and dereliction;
 - 1.13 links existing and proposed landscapes and open spaces together to form open space networks;
 - 1.14 demonstrates how proposed open spaces contribute and respond to the hierarchy of existing landscape and open space networks;
 - 1.15 refers to the Council's open space standards setting out the open space requirements for new developments, in terms of its quantity, quality and accessibility;
 - 1.16 locates open spaces within walking distance so that they are easily accessible to new and existing development;
 - 1.17 locates play spaces to form part of the wider park area rather than an isolated/separate feature.

TEST YOUR DESIGN:

Ensure that the **green and blue infrastructure**:

- 1.18 combines the existing and proposed landscape features to provide a multifunctional landscape eg. incorporate footpaths, mature trees and swales into open space to create a higher quality open space for both people and wildlife;
- 1.19 links landscape features into existing features outside of the site boundary to create a wider network of footpaths, hedgerows, woodlands, rivers and streams, etc.;
- 1.20 has '**Sustainable Drainage Systems**' that is an integral part of the development's open space network.

With respect to **topography and strategic views**, ensure new development:

- 1.21 locates buildings where they work with the existing topography in order to soften the appearance of a new development within the landscape;
- 1.22 retains and enhance views out of a site to prominent landscape features, ridgelines and landmarks;
- 1.23 opens up new views to prominent landscape features, ridgelines and landmarks to enhance identity and legibility.

Meets criteria If not, reason for not meeting

TEST YOUR DESIGN:

With respect to health, well-being and recreation, ensure new development:

- 1.24 create a network of safe and well-designed streets and public spaces that can have a social function as well as accommodating vehicular movement;
- 1.25 provides opportunities for play, social interaction and recreation as well as any formal sports requirements in line with the design guide;
- 1.26 provides the community infrastructure to encourage a legacy of community and cultural activities;
- 1.27 leaves a legacy that allows the resident community to have some control over managing their surroundings;
- 1.28 includes opportunities to encourage local food growing such as community orchards, provision of allotments or other community garden projects;
- 1.29 includes open space which is accessible for all users including people with disabilities, parents/ carers and older people.

With respect to play space, ensure:

- 1.30 the size of the play space facility and the intended age of the children using it has been considered;
- 1.31 any new development uses existing national guidance on inclusive play to ensure play space is accessible to all children.

Meets criteria If not, reason for not meeting

2 TREES AND LANDSCAPING

THE VALUE OF TREES WITHIN THE BUILT ENVIRONMENT

GOAL: To understand the value trees can bring to all developments and integrate them properly to enhance the scheme

Trees in all developments are important and have multiple benefits to all of us and to our whole ecosystem. Not only do they enhance the character and appearance of an area, increasing the draw of the area to local visitors and tourists, there is clear evidence that properties on a tree lined street will have a greater financial value than those without.

The environmental benefits are significant. Trees can assist with climate control through air cooling in summer months, filtering pollutants, improving air quality and adsorbing carbon dioxide. They can also play a key role in reducing surface water flooding and provide valuable habitats and migration routes for wildlife. The social and cultural elements of our lives can be enhanced by the presence of trees. They can form attractive features of our outdoor areas for recreation, the backdrop for relaxing, the inspiration and visual relief along our busy transport routes.

The retention of appropriate mature trees within a development can add a valuable sense of maturity to a scheme. Mature trees will visually soften what can otherwise be a harsh development until new planting is established. Incorporating existing trees into public open space as a focal point in a development will achieve the most benefits as they will be dominant landscape features. Younger trees should be planted at an early stage to allow them to grow naturally.

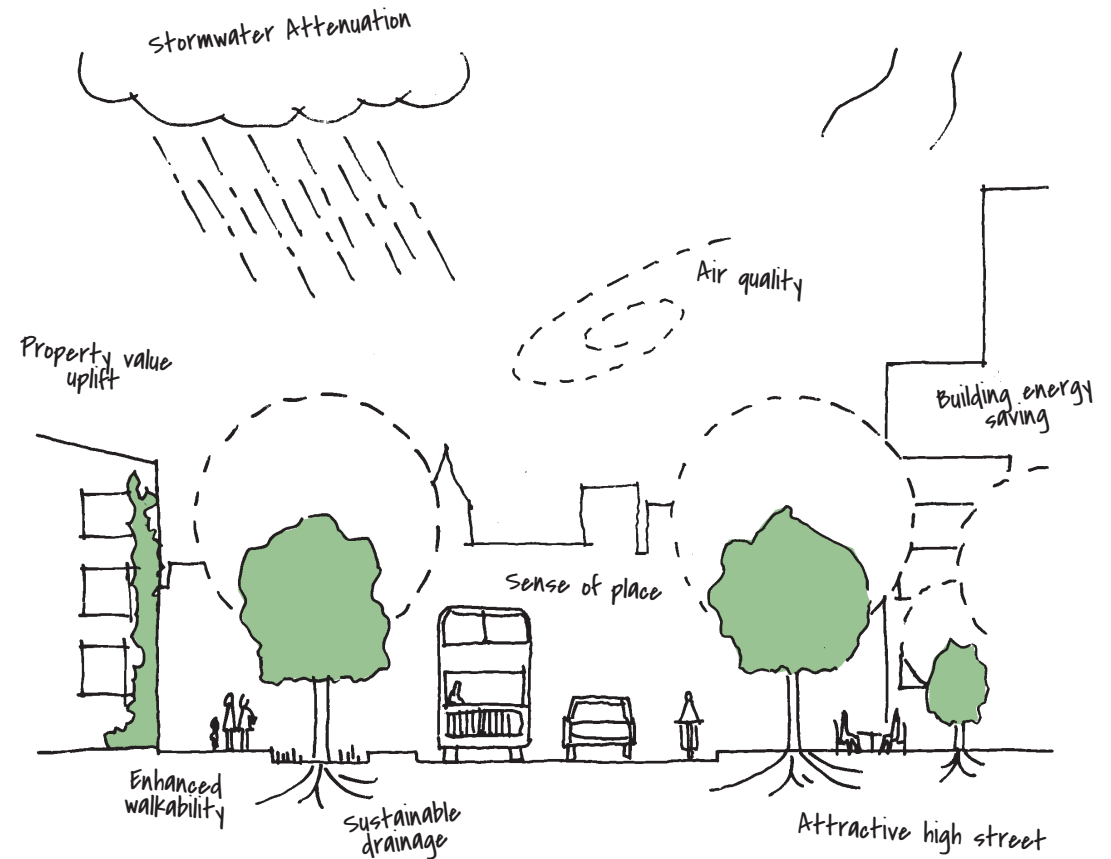

The benefits of tree planting and soft landscaping within the built environment

+ Additional useful and interesting resources:

- British Standard 5837 "Trees in Relation to Design, Demolition and Construction" provides invaluable advice for all stakeholders involved in the design process. Collaboration between arboricultural consultants, drainage / utilities engineers, architects, landscape architects, highways engineers, urban designers, etc will achieve high quality designs, avoiding the common pit falls.
- Lists of consultant arboriculturists can be found on the websites of the Arboricultural Association and the Institute of Chartered Foresters



High value trees incorporated into open space as a key landscape feature for residents and visitors to enjoy (large Cedar, Aston Rowant, South Oxfordshire)



To inform your design:

Technical studies including tree survey, tree protection plan, and an arboricultural method



To communicate your design:

- Prepare a tree protection plan and arboricultural method statement (see checklist);
- Prepare a landscape strategy (see checklist).



TEST YOUR DESIGN:

Ensure that:

- 2.1 the trees on the site have been surveyed by a professional arboriculturist in accordance with the current BS 5837 guidance;
- 2.2 the trees identified as being suitable for retention or removal have been identified and clearly plotted on a scale plan;
- 2.3 there is a tree protection plan and an arboricultural method statement which explains how the retained trees can be protected throughout the demolition and construction process;
- 2.4 a landscape strategy has been written which explains how existing and new trees will can be incorporated into the layout of the new development addressing above and below ground constraints, such as service routes and space for future growth.

Meets criteria If not, reason for not meeting

2 TREES AND LANDSCAPING

LANDSCAPING PLANTING SCHEMES

GOAL: Use planting to help a development integrate into the landscape with its own character and sense of place

New planting is an essential tool for helping a development mature into an integrated part of the landscape with its own character and sense of place. New planting schemes can have multiple uses such as defining a character of an area, or being part of sustainable drainage systems (SuDS) or traffic calming measures, whilst providing the wider range of benefits stated above.

It is essential that all landscaping is designed in coordination with all other above and below ground utilities infrastructure. This will avoid conflicts that would prevent the planting from being implemented or becoming sustained in the future.

The case for trees is compelling but, unfortunately, there is a gap between the desire to plant more trees and the ability to do so. The biggest barrier is the complexity of the urban infrastructure and the competition for space above and below ground.

Trees should be planted for the long term so that they can grow to maturity and deliver their benefits. This means that they need sufficient soil volume to grow in. To make this possible integrated, joined-up thinking and planning is essential so that the use of space both below and above ground is properly thought through and coordinated.

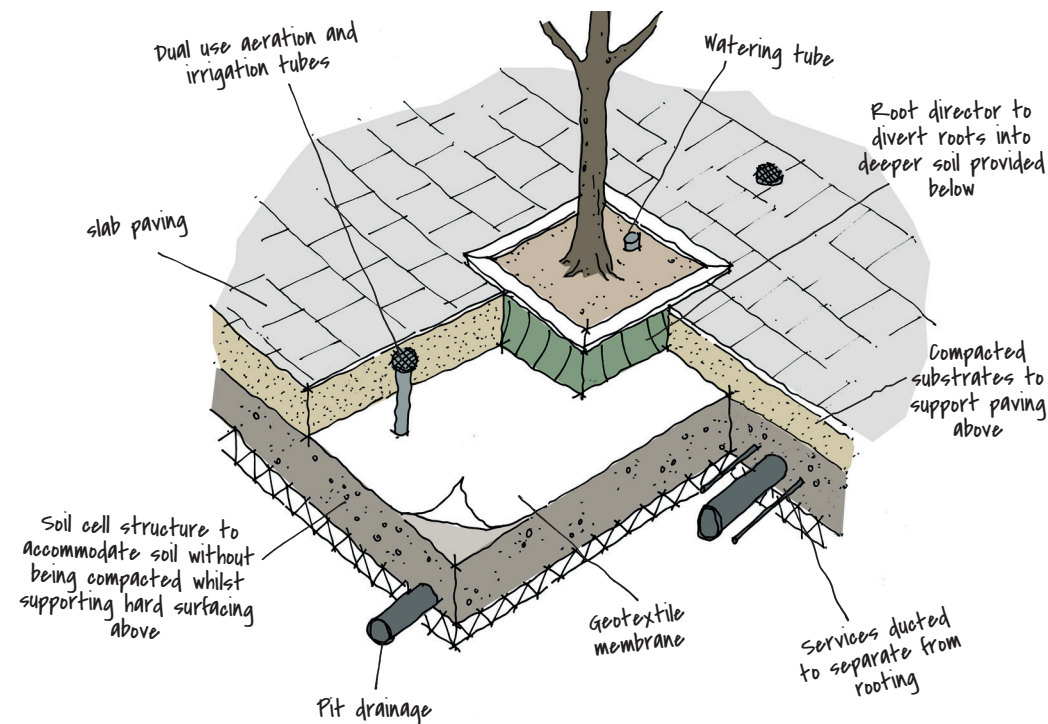

Generic principles to be addressed when designing a tree pit within a hard surfaced environment. Professional guidance should always be sought from the range of professionals.

+ Additional useful and interesting resources:

- The Arboricultural Association
- Institute of Chartered Foresters - Directory of consultants
- The Landscape Institute
- The Trees and Design Action Group (TDAG) in particular Trees in the townscape: A guide for decision makers (November 2012) and Trees in hard landscapes: A guide for delivery (September 2014)

British Standard Documents:

- BS 8545:2014 Trees: from nursery to independence in the landscape – Recommendations
- BS 5837:2012 Trees in relation to design, demolition and construction – Recommendations
- BS 3998:2010 Tree work. Recommendations

Tree Pit Soil Volumes for planting in or adjacent to hard surface areas		
Small Tree Pits	Medium Tree Pits	Large Tree Pits
(For use when planting trees with an expected mature canopy diameter of 3m)	(For use when planting trees with an expected mature canopy diameter of 6m)	(For use when planting trees with an expected mature canopy diameter of 8m+)
4.5 cubic metres per tree*	12 cubic metres per tree*	25 cubic metres per tree*

*The soil must be oxygenated, hydrated and un-compacted to allow for successful tree establishment. Tree pit drainage and ventilation are key components of tree pit design.

Planting is your asset

Tree planting schemes should use a range of species, sizes and regular spacing corresponding to the nature and hierarchy of the street. Designing a site layout around green spaces allowing for the future growth potential of the planting scheme will enable the landscape to mature to its full potential and be a key feature of the development.

Seeing your planting scheme as an asset that can add value to a development rather than just an afterthought once all the site layout has been determined will encourage a holistic design approach. Larger trees species should be used where possible as the benefits they provide are much greater, with relatively little installation cost.

Making the most of your planting by designing tree planting for dual use, such as creating or enhancing a certain landscape character to a development, as well as being a key component of a drainage system is a good use of resources.

A correctly designed tree pit with 30 cubic meters of soil, suitable for a large tree, can have up to 6 cubic metres of water attenuation capacity. To achieve this, it is key to get the drainage engineers on board right at the beginning of the project so that they can incorporate the tree pits within their drainage designs.

Aftercare and maintenance

A key tool to ensure the successful establishment of a planting scheme is aftercare and maintenance programmes, such as a Landscape Management Plan. Seeing your planting scheme as an asset that is worth caring for with simple measures will ensure it achieves its full potential, successful establishment and a return on your investment.



Feature trees to soften the built form (Great Western Park, Didcot and Goring-on-Thames)

Valuable guidance documents



TEST YOUR DESIGN:

Ensure that:

- 2.5 trees have been designed into the layout rather than added after the layout has been fixed. This should be explained in the landscaping strategy;
- 2.6 contact has been made with the Council's Tree Officer to seek advice and guidance;
- 2.7 all landscaping is designed in coordination with all other above and below ground utilities' infrastructure;
- 2.8 the tree planting scheme uses a range of species and sizes, regularly spaced to correspond to the nature and hierarchy of the street and suited to the site's soil type;
- 2.9 a landscape management plan has been prepared and submitted which explains the aftercare and maintenance programme for the landscaping.

Meets criteria If not, reason for not meeting

3 BIODIVERSITY

BIODIVERSITY IN SOUTH OXFORDSHIRE

GOAL: Working with and enhancing biodiversity

Biodiversity simply describes all living things – the variety of life on earth – all plants, animals and the places that they live. The protection and enhancement of biodiversity is a key indicator and component of sustainable development. In the design guide, biodiversity is used to describe important habitats and species which may be affected by, or could be enhanced by development activity.

The aim of this technical guide is to provide basic guidance on what the Council expects in relation to the protection and enhancement of biodiversity related to development proposals. It should give applicants and developers greater certainty and avoid delays in processing planning applications. Information on providing biodiversity enhancements and designing wildlife habitats into new developments can be found throughout the main body of the design guide. There is a wealth of published information available elsewhere which will be referred to and should be used to aid developers in making biodiversity related decisions.

South Oxfordshire contains a rich variety of natural habitats of local, national and international importance. There are a total of 192 designated nature conservation sites in South Oxfordshire including 4 Special Areas of Conservation (SAC), 38 Sites of Special Scientific Interest (SSSI), 150 proposed or confirmed Local Wildlife Sites (LWS) and 4 Local Nature Reserves.

In addition to protected habitats, there are a large number of protected and priority species found in South Oxfordshire. The majority of protected species receive protection as a result of them being rare or of limited distribution, but also as a result of persecution, as is the case with badgers. As a result, it is perhaps unsurprising that the majority of biodiversity issues associated with planning applications arise as a result of the presence of a protected species.

In line with the National Planning Policy Framework, all developments in South Oxfordshire will be expected to contribute to the Governments commitment to halt the loss of biodiversity and deliver net gains where possible.

This guide will provide basic information on the habitats and species most commonly encountered in the planning process as well as laying out the steps that a developer/ applicant will need to take when considering these issues.

Legislation

All protected species and habitats mentioned within this document are covered within one of the following pieces of legislation:

- The Wildlife and Countryside Act 1981 as amended
- The Countryside and Rights of Way Act 2000 (the CRoW Act 2000)
- The Conservation of Habitats and Species Regulations 2010
- The Badgers Act 1992
- The Hedgerow Regulations 1997
- The Natural Environment and Rural Communities Act 2006

Differing procedures and processes will need to be followed depending on the piece of legislation concerned and the penalties for not complying with the legislation will vary accordingly. In addition to the legislation the Council takes a strong stance in the protection of non-statutory sites (LWS) and priority habitats and species.



Watervole



Habitats for butterflies



Additional useful and interesting resources:

- The National Planning Policy Framework (NPPF), particularly chapter 11
- ODPM Circular 6/2005 Biodiversity and Geological Conservation – Statutory Obligations and their impact within the planning system
- Biodiversity - Code of practice for planning and development BS 42020:2013

Protected species

Protected species are present throughout South Oxfordshire and they are the biodiversity issue most often encountered in the planning system. The Council takes a pragmatic approach to protected species issues and will only ask for surveys where it believes that there is a reasonable likelihood of a particular species being present. Protected species occur in many types of habitat although there are clearly some types of application, which have a much higher probability of affecting protected species, and these are outlined in Table 1 of this technical document.

Protected species are a material consideration when the Council is considering a development proposal. Full information about the presence of a protected species will be required before the planning application can be determined. In line with the NPPF, the council will expect developers to provide net gains for species and habitats when considering development proposals.

Applicants are strongly advised to enter into pre-application discussions to ensure all the relevant information is provided before submitting an application. It is important to note that with many species, surveys can only be satisfactorily conducted at certain times of the year when the species is active. Early consultation is therefore important to avoid undue delays to applications arising as a result of the need to carry out surveys within the relevant seasons.

Surveys will not be conditioned as part of a planning permission. Surveys should be carried out by a suitably qualified ecologist and provide sufficient detail to allow the Council to make informed decisions. As a guide the Council would as a minimum require the following information to be provided in the survey:

- What species are involved?
- What is the population level likely to be affected by the proposal?
- What is the impact of the proposal on protected species?
- Is the impact necessary or acceptable?
- What can be done to mitigate the impact?
- Will a licence be required from Natural England?

 **To inform your design:**
Technical studies including ecological surveys

 **To communicate your design:**
- Habitat plans

TEST YOUR DESIGN:

Where protected species are impacted by a proposal, the Council will require the following before it can determine the application:

- | | Meets
criteria | If not, reason
for not meeting |
|---|--------------------------|-----------------------------------|
| 3.1 up to date surveys to an appropriate degree of detail carried out by a suitably qualified ecologist; | <input type="checkbox"/> | <input type="checkbox"/> |
| 3.2 where appropriate, information on how the development will avoid harming the species in its existing location; | <input type="checkbox"/> | <input type="checkbox"/> |
| 3.3 details of measures to enhance the provision of species within the development or create new additional opportunities for that species; | <input type="checkbox"/> | <input type="checkbox"/> |
| 3.4 details of mitigation measures employed to mitigate the harm caused by the development to that species where avoidance is not possible; | <input type="checkbox"/> | <input type="checkbox"/> |
| 3.5 details of the compensation measures to be provided where mitigation is not possible. | <input type="checkbox"/> | <input type="checkbox"/> |

3 BIODIVERSITY

Stages of the planning process for a site where protected species may be present:

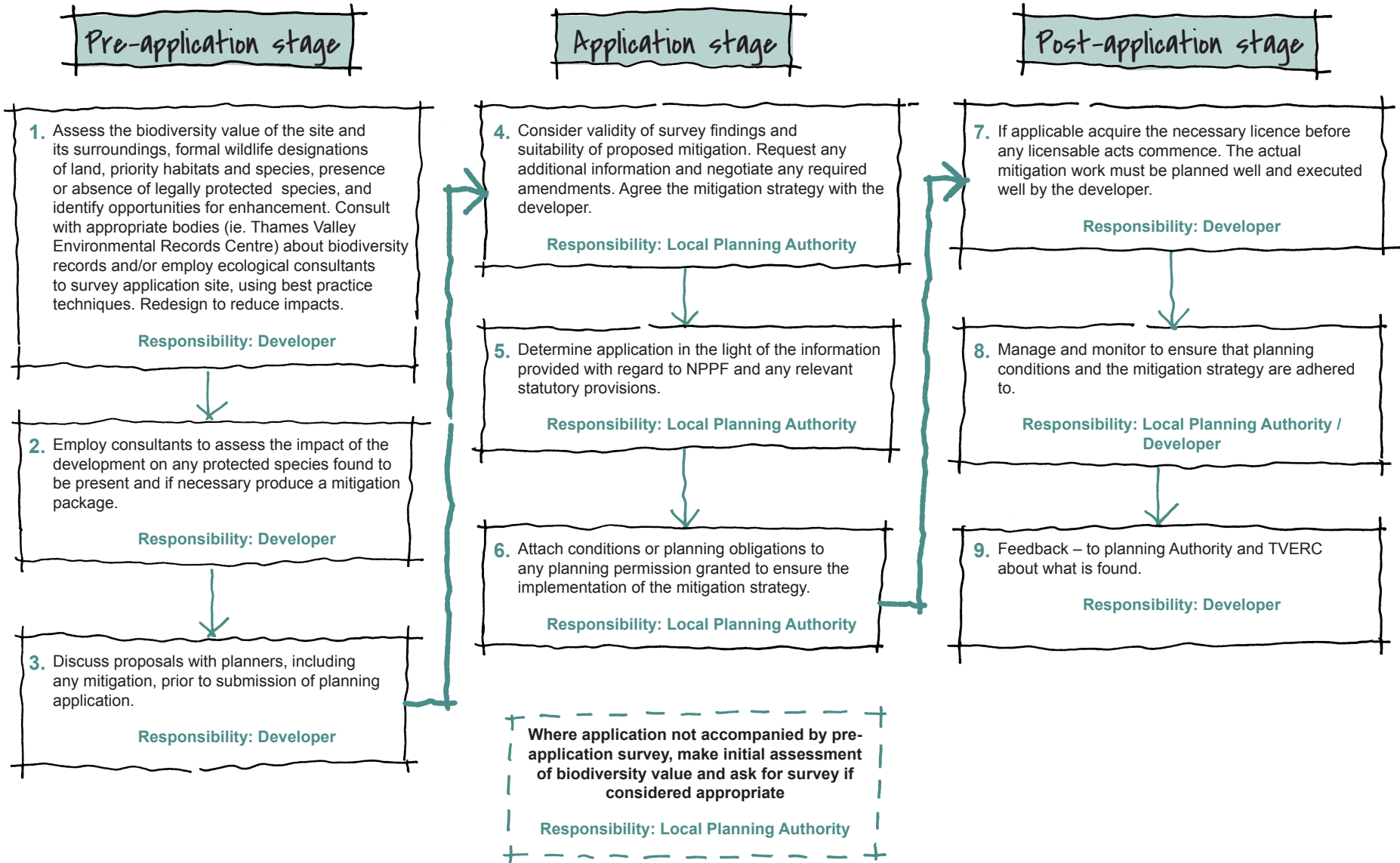

SPECIES

The species most commonly encountered in development proposals in South Oxfordshire are set out in below. This also sets out the issues associated with them, guidance on what can be done and who can help.

Species	What is the issue?	What can I do?	Further information
Bats	The majority of planning cases in South Oxfordshire where a protected species survey is likely to be needed relate to bats. This is because bats are often associated with man made structures and can occur in just about any type of building.	Bat provision can usually be designed into new developments or onversions but it is important that this is identified at an early stage of planning to avoid undue delays.	Bat mitigation guidelines – A.J. Mitchell-Jones http://roost.bats.org.uk/resources/publications Bat Surveys for Professional Ecologists – Good Practice Guidelines 3rd Edition – Bat Conservation Trust (2016) http://www.bats.org.uk/pages/batsurveyguide.html
Great crested newts	Great Crested Newts (GCN) breed in ponds, but spend 5% of their lifecycle on land in long grass or rough vegetation up to 500 metres away. They hibernate in the gaps between stones in walls or rockeries, and in piles of logs. Just about any pond can have GCN resident, from small garden ponds up to farm field ponds. Development sites that do not contain ponds can still be affected if they provide terrestrial habitats for GCN resident in nearby ponds.	Mitigation to avoid damage or disturbance to GCN populations is usually possible. The type and cost of the mitigation is dependant on the population size and the potential impacts of the proposal. Early consultation with the council is advised if there are likely to be any impacts on GCN.	Great crested newt mitigation guidelines – English Nature publication
Nesting birds	All nesting birds receive protection under the Wildlife and Countryside Act 1981, as you may expect nesting birds are found in many places but particular care should be taken where a scheme involves the removal of trees, hedgerows or other dense vegetation. Care should also be taken for work involving roof structures and the eaves of buildings where swifts, swallows and house martins may be present.	In general work which may involve disturbance to nesting birds should only be undertaken outside of the nesting season which runs from the end of February to early August. Where there is a loss of nesting habitat as a result of a development the Council would normally expect appropriate replacement nesting opportunities to be provided as part of the development.	Contact the RSPB: www.rspb.org.uk 01767 693 690 Swift Conservation: http://www.swiftconservation.org/
Barn owls	As the name suggests barn owls are often associated with barns and all types of agricultural buildings but they are also associated with a wide variety of derelict and unused buildings.	Barn owls should not be disturbed whilst they are nesting. The nesting season runs from the beginning of April to the end of September. Nesting and roosting sites should be protected, where it is not possible to avoid impacts developers will be required to provide alternative roosting or nesting locations as near to the original nesting sites as possible.	The Barn Owl Trust: www.barnowltrust.org.uk

3 BIODIVERSITY

Species	What is the issue?	What can I do?	Further information
Badgers	<p>Badgers can be found in woodlands, in areas of scrub, large gardens, (particularly if there are relatively undisturbed) and on undeveloped or brownfield sites within towns. Their setts have large holes which are broadly oval in shape. Badger setts are sometimes confused with enlarged rabbit holes or foxes holes (earth's). If you are unsure contact the council for advice or employ an appropriately qualified consultant to determine what species are involved.</p>	<p>Badgers have very large territories and will use various setts within this area. Mitigation for badgers is often a complex and costly business and it is best to avoid impacting on badger setts and the surrounding areas if at all possible.</p>	<p>Badgers: Surveys and Mitigation for Development Projects https://www.gov.uk/guidance/badgers-surveys-and-mitigation-for-development-projects</p>
Reptiles	<p>All native reptiles are protected. In the district grass snakes and slow-worms are the most often encountered whilst adders and the common lizard are less common.</p> <p>Reptiles can be found on a variety of habitats including urban areas and are often associated with brownfield sites, old railway lines and other open sunny habitats.</p>	<p>As with all protected species it is best to avoid impacts but where this is not feasible it is often possible to provide appropriate mitigation and or compensation to offset any negative impacts.</p>	<p>Reptiles: Guidelines for developers (English Nature, 2004)</p>
Water voles	<p>Water voles are associated with watercourses including canals, rivers, streams, ditches and even sometimes ponds. They are found in both rural and urban areas and although in decline are found throughout South Oxfordshire.</p> <p>Water voles are fully protected. Any development that is likely to either directly or indirectly affect a habitat that has potential to be used by water voles will be expected to provide survey information to determine the presence or absence of the species.</p>	<p>Providing mitigation and compensation measures for water voles is often expensive and time consuming and development impacts on water voles are best avoided.</p>	<p>Water Voles: surveys and mitigation for development projects (Natural England and Department for Environment, Food & Rural Affairs, 2015)</p>
Otters	<p>The population of otters in the district is expanding following the national trend for the recovery of the species. Otters are primarily associated with river systems but occasionally may be found in smaller streams and ditches particularly near where these connect to the main rivers.</p> <p>Any development that affects the banks of rivers should consider the potential for the development to impact on local otter populations.</p>	<p>Developments that are likely to affect otter holts are unlikely to be permitted. Mitigation is often very expensive and complex.</p>	<p>Contact the Environment Agency (01491 828355)</p>

Important note:

Proposals which disturb or in any way affect many of the species above are likely to require a Licence from Natural England and no development will be possible without first obtaining a licence. Licenses are only granted where planning permission has been secured and all relevant conditions discharged.



Great crested newts, brown long ear bat and watervole

HABITAT

Protected habitats are less often encountered in development proposals as their locations are relatively well known and documented. Proposals for development on any undeveloped site (brownfield or greenfield) should consider the potential for direct or indirect impacts on designated sites (this includes statutory and non statutory sites) and priority habitats (as defined in S.41 of the Natural Environment and Rural Communities Act). Information on the location of these sites can be obtained from the Thames Valley Environmental Records Centre (TVERC).

Priority habitats have not all been mapped and it is not uncommon for these to be identified as a result of development proposals. If this is the case the presumption would be against allowing development unless it can be demonstrated that the proposals can avoid impacts on the priority habitats and provide enhancements for the long term. If it is not possible to avoid impacts on priority habitats or provide sufficient on site mitigation then the developer would be expected to provide off site compensation. Biodiversity offsetting is favoured as a means of compensating for the loss of Priority habitats.

Early consultation with the Council is recommended for any development that has direct or indirect impacts on a designated site or priority habitat. Indirect impacts would include things such as disturbance resulting from noise, light, dust or increased pressure from people or their domestic pets.



Wildflower meadows

3 BIODIVERSITY

The types of habitat most commonly encountered in the planning system are listed below:

Habitat	Value	Associated protected species	Advice and references
Ponds	Ponds are a priority habitat. Ponds of all shapes and sizes can have significant ecological value, including small garden ponds and seemingly dry and derelict ponds.	<ul style="list-style-type: none"> - Great crested newts - Water voles - Bats - Reptiles - Invertebrates 	<p>Restoration" of ponds is often not the best option – it is better to create new ponds adjacent to the existing ones to provide a variety of habitats. Where ponds are lost to development new ponds should be created in compensation.</p> <p>http://www.freshwaterhabitats.org.uk</p>
Hedgerows	Native hedgerows provide many important habitat functions such as winter food sources for birds, nesting sites and safe commuting routes connecting otherwise isolated habitats.	<ul style="list-style-type: none"> - Nesting birds - Reptiles - Badgers - Bats - Great Crested newts - Dormice 	Efforts should be made to retain hedgerows within developments. Retained hedgerows should be buffered from surrounding development and not incorporated into domestic boundaries. Where retention is not possible native species rich hedgerows should be provided in compensation.
Rivers, streams, canals and ditches	Watercourses are important wildlife corridors allowing the movement of species throughout the landscape. They are also important habitats in themselves.	<ul style="list-style-type: none"> - Water voles - Great crested newts - Native crayfish - Bats - Reptiles - Fish 	Any development which impacts on a watercourse either directly or indirectly may need the consent of the Environment Agency and it is best to contact them early in the planning process.
Wildflower grasslands	Some of the most diverse habitats in the district occur on the chalk grassland of the Chilterns and North Wessex Downs as well as the rich riverside meadows along the Thames.	<ul style="list-style-type: none"> - Nesting birds - Reptiles - Invertebrates 	Most of the important grasslands are within designated sites and development of these areas should be avoided. If priority habitat grasslands are identified on development sites then the developer should consider how to avoid direct or indirect impacts. Mitigation should be provided where impacts cannot be avoided and as a last resort compensation will be required if it is not possible to demonstrate a net gain in biodiversity.

Habitat	Value	Associated protected species	Advice and references
Ancient or veteran trees	Old trees provide habitats for many species as well as being important landscape features in themselves.	<ul style="list-style-type: none"> - Bats - Nesting birds - Invertebrates 	Impacts on ancient or veteran trees should be avoided wherever possible. Applications involving the loss or deterioration of ancient trees will be strongly resisted.
Woodlands	Ancient woodlands are irreplaceable habitats which are widespread across the district.	<ul style="list-style-type: none"> - Bats - Nesting birds - Badgers - Dormice - Reptiles - Invertebrates 	<p>Impacts on ancient woodland should be avoided. Mitigation for impacts is generally difficult. The diverse nature and structure of ancient woodlands means that replacement planting is generally not considered to be adequate mitigation / compensation.</p> <p>Applications involving the loss or deterioration of ancient woodlands will be strongly resisted.</p>
Traditional orchards	Traditional Orchards are a priority habitat.	<ul style="list-style-type: none"> - Bats - Nesting birds - Badgers - Dormice - Reptiles - Invertebrates 	Traditional fruit tree orchards and cobnut plants, whilst of artificial origin, have often escaped agricultural intensification and are important refuges for a wide range of wildlife. The total area of traditional orchards has declined drastically in recent years and the conservation of the remaining orchards is a high priority.

3 BIODIVERSITY

PLANNING POSITIVELY FOR BIODIVERSITY

Biodiversity enhancement is the target outcome for all planning decisions, with a no net loss in biodiversity resource being the minimum standard. Paragraphs 109 and 117 of the NPPF seek to achieve a no net loss of biodiversity with enhancements wherever possible. This has been translated into local policies within the local plan and core strategy.

The Council applies a form of Biodiversity Accounting to help it understand if development proposals are able to achieve the policy requirements. Biodiversity accounting takes account of the biodiversity value of the site prior to the development (baseline condition) as described in the biodiversity survey report. It then values the site post development, including any specific or inherent mitigation to determine if the proposals meet policy requirements.

Where proposals do not achieve a no net loss, the Council will seek amendments to the scheme to avoid impacts and / or, to increase the level of mitigation so that the proposals can demonstrate no net loss. Where net loss is unavoidable, the Council may require the developer to provide offsite compensation by entering into a Biodiversity Offsetting agreement or through other offsite works designed to compensate for the value of biodiversity lost. Offsetting or other compensation are not appropriate for dealing with impacts on protected species or designated sites. In certain circumstances where no net loss cannot be adequately demonstrated and compensation proposals are inappropriate or inadequate, the Council may refuse planning permission.

In order to ensure that development proposals meet the policy requirements we recommend that biodiversity requirements are considered early in the design process. All good ecological consultants should be able to advise on how to ensure your proposals achieve no net loss.

Biodiversity calculators:

There are a number of freely available biodiversity impact calculators which can help you and your ecological advisors to ensure that your proposal meets the policy requirements:

- Warwickshire impact calculator
- Environment bank impact calculator

We recommend that you work with your ecological advisors to run development proposals through an impact calculator prior to submitting a planning application to determine if it meets the policy requirements.

There are several different types of common biodiversity enhancements which cannot be easily quantified in biodiversity calculators, such as the addition of bat boxes or artificial bird nesting sites. Where the use of these features is considered appropriate and they will contribute to the site's biodiversity value, the Council will take a pragmatic approach and will give them appropriate weight in coming to a decision (for example on urban sites where there are few other options).



Incorporate wildflower meadows into new development



Biodiversity enhancement by integration of blue infrastructure (Courtesy of CIRIA, SuDS in Cambridgeshire)



Barn owl



Insect hotel (Didcot)

THE USE OF PLANNING CONDITIONS

In certain circumstances, the council may use planning conditions to ensure that a development proposal achieves a no net loss or a net gain for biodiversity.

Where the council considers that proposals have the potential to achieve policy compliance but the applicant has not submitted sufficient detail to allow a detailed assessment to be made we will consider attaching a planning condition requiring the submission of a Biodiversity Enhancement Strategy.

The Biodiversity Enhancement Strategy will need to be prepared in conjunction with the detailed landscaping scheme to ensure that the proposed enhancements work in conjunction with the landscaping proposals.

In assessing an application to approve the details required by condition for a Biodiversity Enhancement Strategy, the council will use the Biodiversity Accounting principles described above. A Biodiversity Impact Calculator will be used to determine if the proposals meet the requirements of the condition. We recommend the use of impact calculators (see page 20) prior to the submission of details required by condition to check your proposals are likely to meet the condition requirements.

+ Additional useful and interesting resources and relevant contacts:

- The BS 42020:2013 Biodiversity - Code of practice for planning and development.

British Standards Institute:

- Guidelines for Ecological Impact Assessment in the United Kingdom - IEEM 2016

Key contacts:

- Thames Valley Environmental Records Centre (TVERC), c/o Oxfordshire County Council, Signal Court, Old Station Way, Eynsham, OX29 4TL. Tel: 01865 815451.
tverc@oxfordshire.gov.uk

4 SUSTAINABLE ENERGY

ACHIEVING OPTIMAL ENERGY USAGE

GOAL: To make the best use of the entire site's potential for optimising natural energy resources

You need to identify, early on in the design, opportunities to maximise sunlight and daylight penetration whilst not conflicting with the overall structure of the development. This will provide the maximum opportunity to incorporate active solar energy systems (either thermal or for power generation) thereby reducing energy demand. Account needs to be taken of the effects of shading where existing features such as large trees or a copse are retained.

By co-locating any major heat sinks such as large commercial buildings or care homes, you should consider the potential of heat grids or micro-grids using a centralised energy source as a supply solution. This could be a heat only or a combined heat and power (CHP) system using natural gas or biomass.

Consideration should be given to linking energy solutions with large consumers (or generators) adjacent to the site, particularly where an infill site is concerned. This may give an energy scheme sufficient scale to merit a more sustainable and economically sound approach to be realised.



Example of a roof based solar PV scheme

+ Additional useful and interesting resources:

- Sustainable Energy by Design, TCPA, www.tcpa.org.uk
- Energy efficiency in historic buildings (Historic England, 2015)



To inform your design:

Technical studies including estimates of energy requirements showing how these have been minimised



To communicate your design:

- An assessment with assumptions showing supply options clearly set out.



Small-scale hydro (Scotland)



Example of an extensive green roof (Maidenhead)



Example of a vertical green wall (Madrid)

TEST YOUR DESIGN:

A plan has been prepared that identifies the following within and beyond the site boundaries:

- 4.1 the orientation of buildings to allow the use of solar technology on roofs and to maximise the potential for solar gain;
- 4.2 the size and relative locations of all major energy consumers within the development site and adjacent to the site;
- 4.3 areas designated for energy infrastructure including that for proposed generation showing adequate access has been created;
- 4.4 the inclusion of renewable energy technologies to reduce the site's conventional energy needs;
- 4.5 using natural or passive ventilation techniques to improve well-being and further reduce energy needs.

Meets criteria If not, reason for not meeting

4 SUSTAINABLE ENERGY

MINIMISING ENERGY CONSUMPTION

GOAL: Making best use of energy for small developments or single properties

Using green roofs and green walls in a development can provide variety and reduce urban overheating as well as having a beneficial impact on water runoff and biodiversity. Making use of rainwater through harvesting technologies also reduces runoff and will increase overall site sustainability by reducing water demand.

An energy plan should be prepared and demonstrate how sustainable technologies might be used with, or instead of, more conventional forms of energy such as natural gas. Technologies to be considered within the plan should include (but not be limited to): solar photovoltaics (PV), solar thermal, biomass or woodfuel, heat pumps (air, ground or water if near a watercourse or river), hydro, wind and fuel cells.



Sustainable energy technologies such as wind and solar (Westmill, Oxfordshire)



To inform your design:

An estimate of energy requirements showing how these have been minimised.



To communicate your design:

- An assessment with assumptions showing supply options.



Additional useful and interesting resources:

- BRE centre of expertise on buildings www.bre.co.uk



An example of solar roof tiles (Stroud, Gloucestershire)



Wood chipping and biomass boiler as alternatives to conventional energy sources (Thames Valley and Oxfordshire)

TEST YOUR DESIGN:

A plan has been prepared that shows how the following energy related matters have been considered:

- 4.6 which technologies (including renewables) are appropriate to supply heat and power to all or to a part of the development or house extension;
- 4.7 the use of passive design features such as sun pipes and atria to reduce energy demands for lighting and heating;
- 4.8 the use of materials of differing thermal mass to reduce energy demand;
- 4.9 maximise the reuse and recycling of materials including materials existing on site;
- 4.10 siting of any green or brown roofs or walls as well as rainwater harvesting to reduce overall water demand;
- 4.11 re-use grey water which can be installed in new or existing properties and have the potential to meet significant proportion of domestic demand for water.

Meets criteria If not, reason for not meeting

<input type="checkbox"/>	<input type="checkbox"/>
<input type="checkbox"/>	<input type="checkbox"/>
<input type="checkbox"/>	<input type="checkbox"/>
<input type="checkbox"/>	<input type="checkbox"/>
<input type="checkbox"/>	<input type="checkbox"/>
<input type="checkbox"/>	<input type="checkbox"/>

5 PUBLIC ART

INCORPORATING PUBLIC ART INTO NEW AND EXISTING DEVELOPMENTS

GOAL: Incorporate public art into developments to enhance the visual quality and richness of a place, create a sense of pride and identity.

South Oxfordshire District Council supports active public art policies as it firmly believes that working with artists can enhance physical spaces, create identity and pride and welcome new residents to new community settings. This helps achieve one of the council's ambitions to deliver our key services, support our communities and improve facilities within the district.

Public art needs to be taken into consideration at the outset of the design process, be of local relevance/significance to ensure it makes a valuable contribution to the character and success of a development. Public art is art for the public specifically designed by artists for the purpose of public display (i.e. it is beyond the artist's work merely shown in public spaces). Public art is always site-specific and can take many forms that may include sculptures, fencing, paving, (this is covered under street furniture), street furniture, mosaics, glass work, flooring, lighting gateways or even community events.

Public art provides a great mechanism for leisure and planning to meet the broader Council's corporate objectives. Public art features can be accepted as part of a planning application or worked as a project within the design and build of a scheme, sometimes secured via Section 106 or through Community Infrastructure Contributions (CIL), or incorporated within a planning application.



Public art in the form of paving (Oxford and Drayton, Oxfordshire)

+ Additional useful and interesting resources:

- South And Vale of White Horse District Council Public Art Policy
- Oxfordshire Arts Partnership Public Art Commissioning Guidelines
- Public Art online
- Association for Public Art



To inform your design:

Original brainstorming of ideas



To communicate your design:

The evolution of your design from initial concept to final design



Sculptural art can be integrated in the public spaces at various scales (Didcot and Milton Keynes)

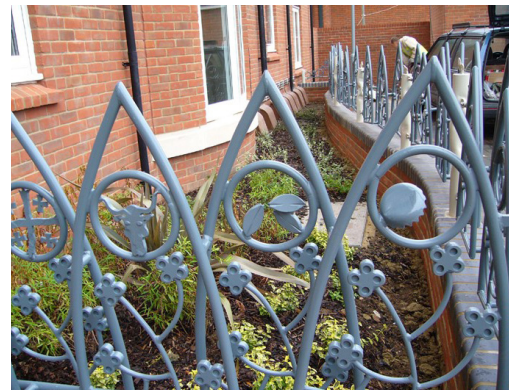

Public art integrated into boundary treatment (Great Western Park and Abingdon)

TEST YOUR DESIGN:

Ensure that works of art commissioned in any new development:

- 5.1 are of the highest quality;
- 5.2 are designed and created by professional artists;
- 5.3 have local relevance/significance (if not to the site then to the local area);
- 5.4 are informed by public participation and involvement where appropriate;
- 5.5 are informed by liaison and development with the Arts Development Officer.

Meets criteria If not, reason for not meeting

<input type="checkbox"/>	<input type="text"/>
<input type="checkbox"/>	<input type="text"/>
<input type="checkbox"/>	<input type="text"/>
<input type="checkbox"/>	<input type="text"/>
<input type="checkbox"/>	<input type="text"/>

6 HOUSEHOLDER EXTENSIONS AND OUTBUILDINGS

RESPECTING THE CHARACTER AND APPEARANCE OF THE EXISTING DWELLING AND THE LOCAL AREA

GOAL: To achieve extensions to dwellings that respond to the needs of the occupants in a way that is sensitive to the character and appearance of the original dwelling and street scene

Extensions to dwellings can have a significant impact on the character and appearance of a dwelling itself and the street or area in which it is set. A well-designed extension can enhance the appearance and value of a property, whereas an unsympathetic extension can have a harmful impact, create problems for neighbouring residents, and affect the overall character of the area.

Some smaller-scale extensions may constitute 'permitted development' which means they do not need planning permission (see useful guidance). If planning permission is not required, we would still strongly encourage you to follow the best practice guidance in this document to ensure that the design of your extension can be the best that it can be.

If a building has been identified as being Statutorily Listed or is located within a Conservation Area or AONB, some forms of development or alteration that would otherwise be classed as permitted development will require planning permission, Listed Building consent or combinations of these. A Design and Access Statement may need to be submitted for applications for Listed Building consent and for planning applications in Conservation Areas. Extensions to historic buildings can be harmful if their significance is not fully understood.

The Council can provide further assistance and guidance about what does and does not require planning permission and advice about the design of the proposal.

+ Additional useful and interesting resources:

- Planning portal: Information about permitted development and how to submit your application
- Pre-application advice service
- Validation checklist
- Southvale Building Control Service



Extension in keeping with the existing character and appearance of the house (Kingston Blount)



To inform your design:

Technical studies including (but not limited to) surveys on trees, habitats, species etc. where appropriate.



To communicate your design:

- Clear elevations, roof plans, floor plans
- A block plan and/ or landscape plan with a clear legend
- Three dimensional models
- Sunlight/ daylight diagram

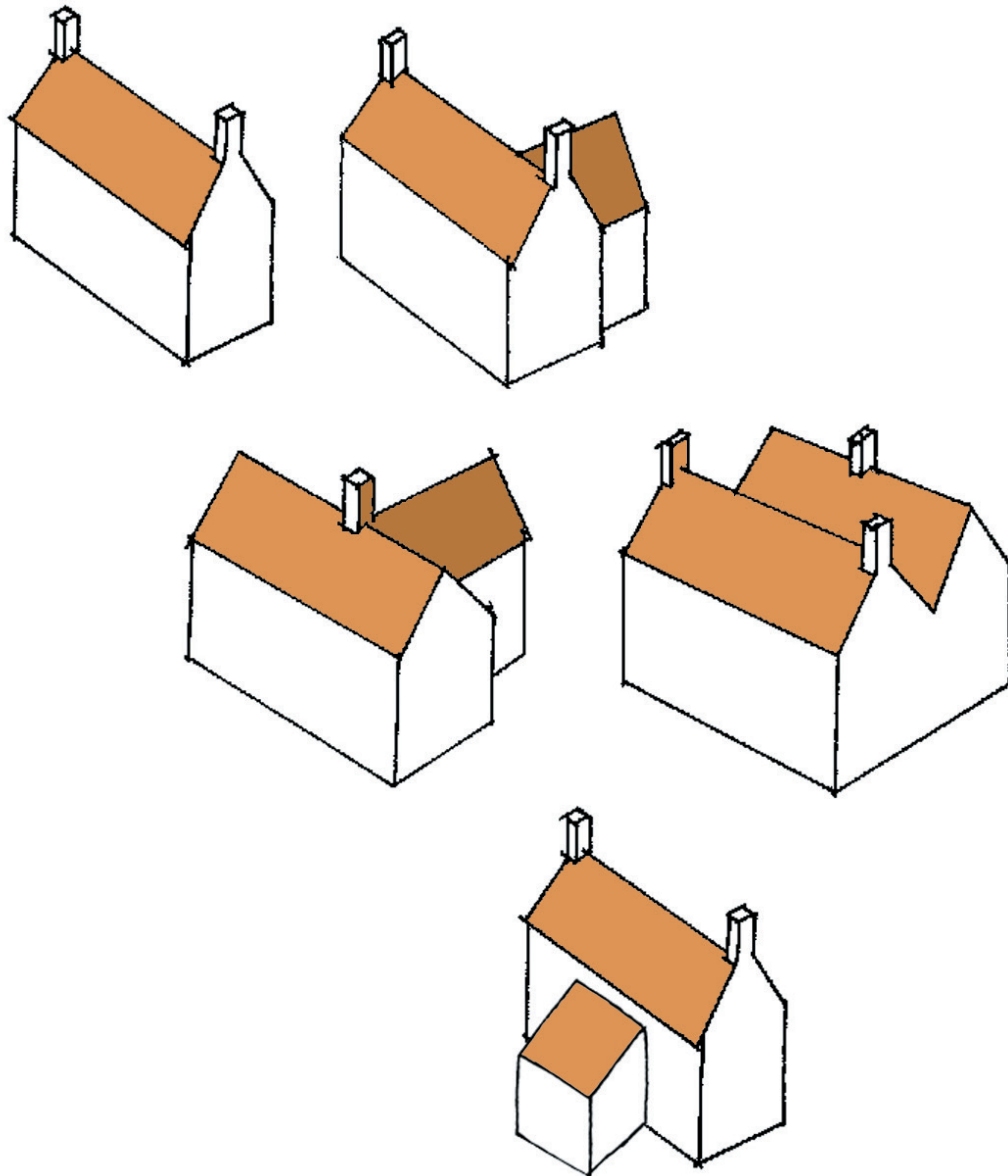

Good examples for different configurations of extensions which respect the form of the existing building and use simple, uncomplicated building lines

TEST YOUR DESIGN:

General advice for all extensions and alterations

The following design principles are relevant to all types of householder extensions and alterations:

Character and appearance

- 6.1 responds to and respects the character and appearance of the area and street scene;
- 6.2 maintains established building lines;
- 6.3 uses simple, uncomplicated building forms that compliment and coordinate with the scale, form and massing of the original dwelling;
- 6.4 uses building materials which match those of the existing dwelling or justification has been provided which explains the appropriateness of the alternatives proposed?;
- 6.5 ensures the original building remains the visually dominant element of the property (whether it is an extension, a self-contained annex, an outbuilding or a garage);
- 6.6 has a roof form appropriate to the original dwelling. Generally this should be constructed with the same angle of pitch as the existing roof;
- 6.7 ensures any existing external access from the front to the rear garden has been retained;
- 6.8 responds to the existing pattern of window and door openings? Note that the position, size, proportion, height and style of new windows and doors and the ratio of solid wall to openings all help to define the character of a dwelling;

Meets criteria If not, reason for not meeting

<input type="checkbox"/>	<input type="checkbox"/>
<input type="checkbox"/>	<input type="checkbox"/>
<input type="checkbox"/>	<input type="checkbox"/>
<input type="checkbox"/>	<input type="checkbox"/>
<input type="checkbox"/>	<input type="checkbox"/>
<input type="checkbox"/>	<input type="checkbox"/>
<input type="checkbox"/>	<input type="checkbox"/>
<input type="checkbox"/>	<input type="checkbox"/>
<input type="checkbox"/>	<input type="checkbox"/>

Conservation areas and listed buildings

- 6.9 If the proposed extension is within a conservation area or is part of a listed building, does the proposed design enhance the original features or contribute to its significance?

6 HOUSEHOLDER EXTENSIONS AND OUTBUILDINGS

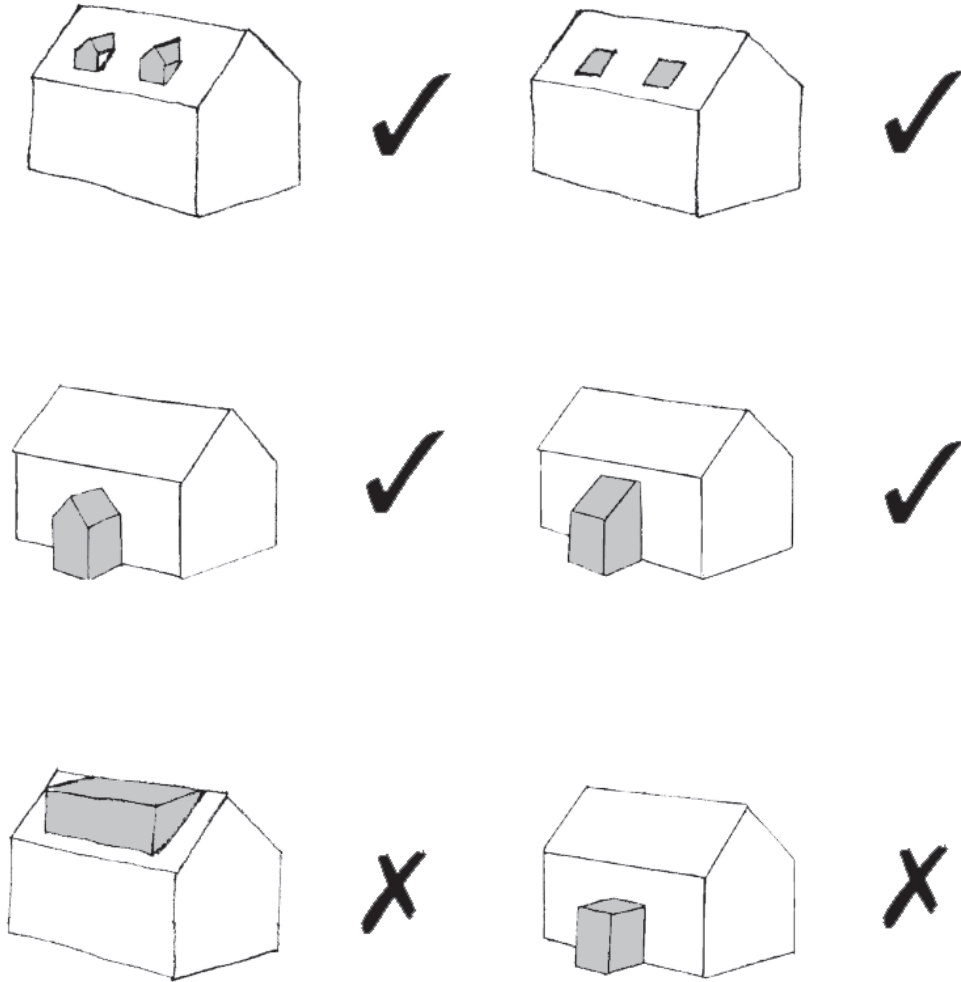

TEST YOUR DESIGN:

Impact on neighbours

All proposals must take into account the potential impact on neighbours. The proposal:

- 6.10 has been informed by the positioning of neighbouring dwellings and an understanding of the potential impact development could have upon them;
- 6.11 can demonstrate that it will not result in overshadowing, a loss of privacy or an oppressive or overbearing impact on neighbouring properties;
- 6.12 there is a minimum of 12m between habitable windows and flank walls;
- 6.13 complies with the 45 degree rule set out within the BRE guidance;
- 6.14 must not result in a significant loss to the private amenity area of the existing dwelling.

Front extensions and canopies

- 6.15 Front extensions will be resisted where they have a significant impact on the street scene or are damaging to the appearance of a dwelling. Modest front extensions that reflect the character of the existing property are more likely to be acceptable;
- 6.16 When located close to a neighbouring property, front extensions should not have a negative impact on the amount of light afforded to that property, nor should it have an over bearing impact. Front extensions are more likely to be acceptable where the building line is staggered or where the dwelling is set well back from the road;
- 6.17 They should normally be designed with a pitched roof to be as close to that of the main roof as possible;
- 6.18 Avoid large, flat-topped porches.

Meets criteria If not, reason for not meeting

<input type="checkbox"/>	<input type="checkbox"/>
--------------------------	--------------------------

<input type="checkbox"/>	<input type="checkbox"/>
--------------------------	--------------------------

<input type="checkbox"/>	<input type="checkbox"/>
--------------------------	--------------------------

<input type="checkbox"/>	<input type="checkbox"/>
--------------------------	--------------------------

<input type="checkbox"/>	<input type="checkbox"/>
--------------------------	--------------------------

<input type="checkbox"/>	<input type="checkbox"/>
--------------------------	--------------------------

<input type="checkbox"/>	<input type="checkbox"/>
--------------------------	--------------------------

<input type="checkbox"/>	<input type="checkbox"/>
--------------------------	--------------------------

<input type="checkbox"/>	<input type="checkbox"/>
--------------------------	--------------------------

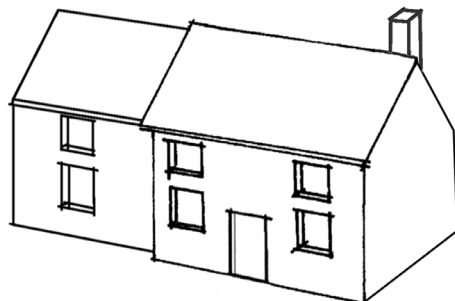
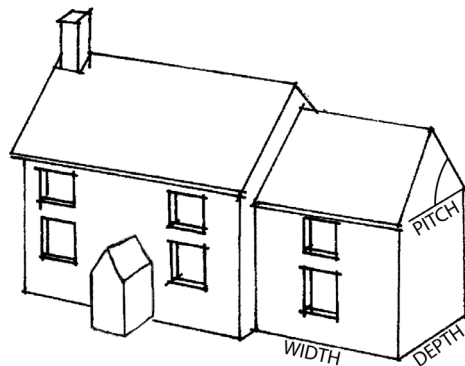
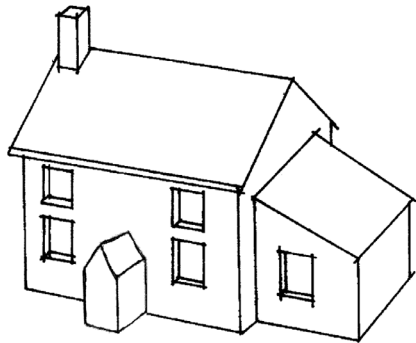

Acceptable examples for side extensions



Successful contemporary extensions to traditional buildings in Watlington and London

TEST YOUR DESIGN:

Side extensions

The side extension must:

- 6.19 be set back from the front of the house or otherwise justified for not doing this;
- 6.20 retain important gaps within the street scene and avoid creating a 'terracing effect';
- 6.21 be constructed with the same angle of pitch as the existing roof;
- 6.22 be subordinate to the principle dwelling;
- 6.23 include windows that face the street to provide passive surveillance;
- 6.24 can demonstrate that it will not result in overshadowing, a loss of privacy or an oppressive or overbearing impact on neighbouring properties.

	Meets criteria	If not, reason for not meeting
6.19	<input type="checkbox"/>	<input type="text"/>
6.20	<input type="checkbox"/>	<input type="text"/>
6.21	<input type="checkbox"/>	<input type="text"/>
6.22	<input type="checkbox"/>	<input type="text"/>
6.23	<input type="checkbox"/>	<input type="text"/>
6.24	<input type="checkbox"/>	<input type="text"/>

6 HOUSEHOLDER EXTENSIONS AND OUTBUILDINGS

REAR EXTENSIONS

Rear extensions should not result in significant overshadowing of a neighbour's property.

Rear extensions which are not visible from the street and do not negatively impact on neighbouring properties can be expressed in many forms, including through the use of contemporary architecture.

In addition to the distance between properties, there are a number of solutions that can be employed to maintain privacy from the placement of buildings and design of buildings, to more detailed design measures such as appropriate positioning of windows (staggered or otherwise), arrangement of habitable rooms to reduce direct views; and creating varied floor levels.

As a general rule, extensions that alter the existing ridge of the roof or significantly alter the roof profile will not be accepted where this detracts from the character and appearance of the original dwelling and/or the street scene.

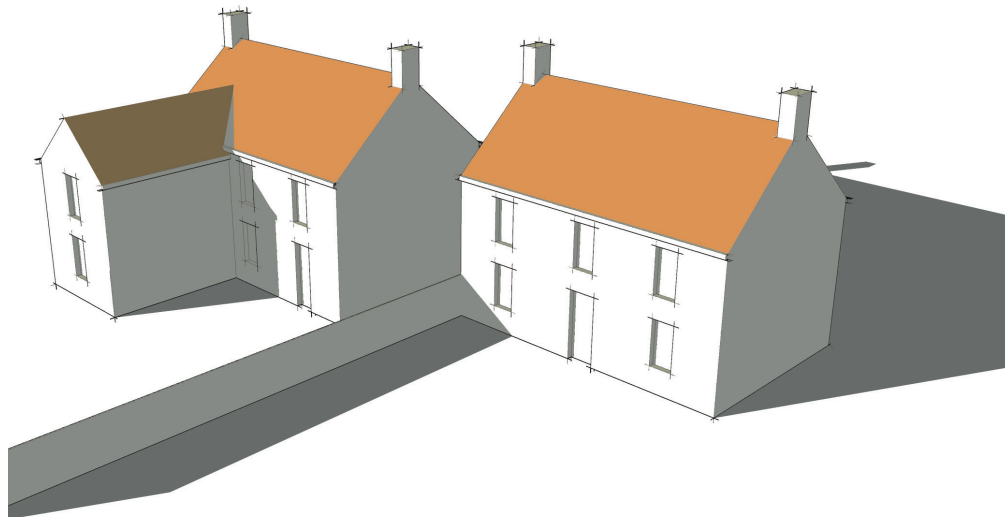

TEST YOUR DESIGN:

Rear extensions

Rear extensions should:

- 6.25 avoid a detrimental impact on the existing dwelling's usable garden area;
- 6.26 must not have a harmful effect on neighbouring properties in terms of privacy, overshadowing or overbearing impact;
- 6.27 provide an adequate distance between facing habitable rooms to help people feel comfortable in their homes;
- 6.28 can demonstrate that it will not result in overshadowing, a loss of privacy or an oppressive or overbearing impact on neighbouring properties;
- 6.29 comply with the 45 degree rule as set out overleaf.

Meets criteria If not, reason for not meeting

<input type="checkbox"/>	<input type="checkbox"/>
<input type="checkbox"/>	<input type="checkbox"/>
<input type="checkbox"/>	<input type="checkbox"/>
<input type="checkbox"/>	<input type="checkbox"/>
<input type="checkbox"/>	<input type="checkbox"/>

Loft conversions and roof extensions

- 6.30 Dormer roof extensions must be set within the roof slope;
- 6.31 Two or three smaller dormers are often more successful than a single large flat roofed, boxy dormer;
- 6.32 The position and proportion of dormer windows should respond to existing windows and/or doors;
- 6.33 Roof lights should be used sparingly and where they are less likely to be visible in the street scene, such as to rear elevations or in discreet roof valleys. In sensitive locations such as on Listed Buildings and in Conservation Areas, 'conservation type' roof lights should be used.

<input type="checkbox"/>	<input type="checkbox"/>
<input type="checkbox"/>	<input type="checkbox"/>
<input type="checkbox"/>	<input type="checkbox"/>
<input type="checkbox"/>	<input type="checkbox"/>

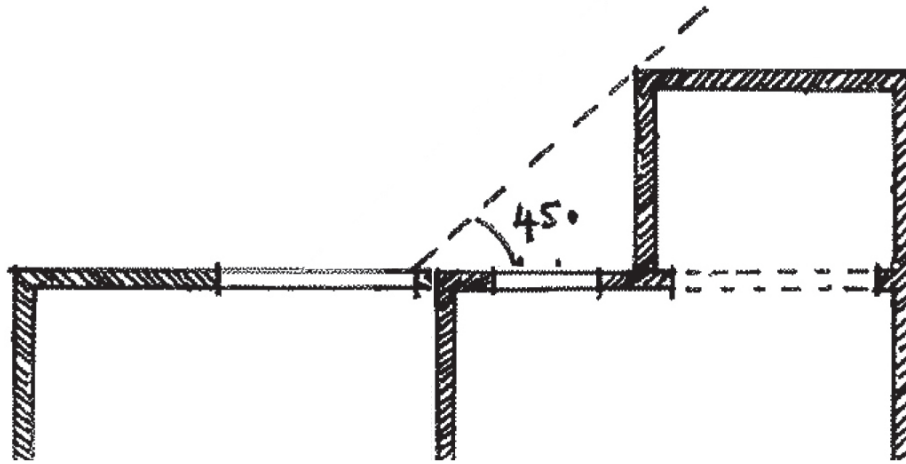

Diagram showing 45 degree angle rule

+ Additional useful and interesting resources:

- National Planning Policy Framework
- Planning Portal
- Validation checklist (if planning permission is required)
- Permitted development request
- Southvale Building Control Service
- Historic England practice guides such as making 'Making changes to your property'

TEST YOUR DESIGN:

Garages and outbuildings:

- 6.34 Garages should be simple functional buildings, of moderate size and scale. They should not compete with the main dwelling in terms of their footprint or height and should avoid dormer windows and other domestic features;
- 6.35 The size, siting and scale of any outbuilding should not compete with the main dwelling;
- 6.36 Swimming pools, associated pump equipment and tennis courts should not be sited where they will cause noise and disturbance to nearby neighbouring dwellings.

Meets criteria If not, reason for not meeting

7 BUILDING CONVERSIONS

CONVERTING EXISTING BUILDINGS WORTHY OF RETENTION

GOAL: To make sure that buildings that are no longer used or vacant are re-used wherever possible in order to preserve their contribution to settlements and the countryside and in turn making it a more sustainable option

There are many buildings throughout South Oxfordshire within settlements and in the countryside that are no longer used or are vacant. These buildings include farm buildings, factories, chapels, schools and mills. The reuse of existing buildings within South Oxfordshire is a key objective in terms of preserving their contribution to settlements and the countryside but also in sustainability terms. The embodied energy in a building's fabric is considerable. For example, it takes a lot of energy to demolish and rebuild existing buildings. With this in mind, the council seeks to encourage the re-use of buildings wherever possible particularly when the building makes a positive contribution to the character of an area.

Their conversion and re-use however must be done with great care in order to ensure that the essential character of the original building is not lost or that the contribution the building makes to the wider area is not compromised. This technical document examines the design approaches that should be adopted when converting a range of existing building types. It should be noted that conversion to residential use is not always the most appropriate solution, particularly where the building is listed or is situated in an isolated location in the open countryside. Compliance with building regulations is also a key consideration for any building conversion and may require significant alterations to the original building. In these cases the council may consider the conversion of the building as not appropriate or acceptable.

+ Additional useful and interesting resources:

- National Planning Policy Framework and the development plan
- Validation checklist
- Planning Portal and Southvale Building Control Service
- Energy efficiency in historic buildings (Historic England, 2015)
- Historic England provides extensive guidance and information on working within the historic environment. Some of these include Conservation Principles; Conversion of Traditional Farm Buildings; Good Practice Advice Notes



Examples for existing building conversions (Wolverton and Wallingford)



To inform your design:

Technical studies including (but not limited to) surveys on trees, habitats, species etc. where appropriate



To communicate your design:

- Elevations if there are external changes and floor plans
- Block plan and/ or landscape plan



Conversion of an existing chapel in Kingston Blount



Converted farm buildings (Crowmarsh Battle Farm)



TEST YOUR DESIGN:

All types of conversion should consider:

- 7.1 a structural report will need to be submitted with any planning application to demonstrate that the building is capable of conversion without substantial rebuilding or extension;
- 7.2 an assessment should be made as to the existing character and the impact of a proposed conversion on any special interest, as per the NPPF, and through the contextual analysis (see design guide);
- 7.3 the conversion must retain the character and appearance of the original building;
- 7.4 the introduction of conspicuous domestic features should be avoided;
- 7.5 existing openings in elevations should be used for windows and doors;
- 7.6 new windows or doors should be added sparingly and should not significantly alter the overall proportion of solid wall to openings;
- 7.7 a simple window design is usually most appropriate;
- 7.8 where additional floors are introduced, they should not cut across tall windows;
- 7.9 when appropriate, existing ecclesiastical fixtures and fittings should be retained wherever possible;
- 7.10 when appropriate, existing commercial or industrial fixtures and fittings should be retained wherever possible;
- 7.11 when introducing new materials, these should respond to established character and be compatible with both the existing materials and building type: for example; lime finishes, traditional weatherboarding, natural roofing and wall materials, etc.;
- 7.12 consider accessibility of conversions.

Meets criteria If not, reason for not meeting

8 SHOPFRONTS AND SIGNAGE

SHOPFRONT DESIGN

GOAL: To make sure that shopfronts are in keeping with the character of the building and street scene, reflect the scale and proportion of the building in which it is set and preserve and restore surviving historic shopfronts in a sensitive manner

The design details of traditional shopfronts have their roots in the display of goods in medieval market stalls, although the shopfront as we now recognise it emerged only with the expansion of commercial activity in the 18th century. Today we have a rich heritage of traditional shopfront design, particularly from the 19th and early 20th centuries.

Traditional shopfronts in our district are increasingly threatened by the decline of the small individual retail outlet and the rise of larger stores with standard corporate images. However, it is possible to integrate the needs of retail units and pay regard to the character of the building or surrounding streetscape.



Example of a traditional shopfront (Thame, Oxfordshire)



To inform your design:

Conservation appraisals and contextual analysis



To communicate your design:

The evolution of your proposal from initial concept to final design



Additional useful and interesting resources:

- Traditional shopfront guide strikethrough version of the 1995 guide (2016)
- Building Regulations Part M: Access to and use of buildings



Basic elements of a traditional shopfront



3 Bell Street, Henley before refurbishment



3 Bell Street, Henley after refurbishment

TEST YOUR DESIGN:

Elements of good design:

Ensure your proposal:

- 8.1 recognises the need to advertise the goods and services offered but also respects the character of the building and street scene;
- 8.2 understands that a shopfront should reflect the scale and proportion of the building in which it is set;
- 8.3 preserves and restores surviving historic shopfronts in a sensitive manner;
- 8.4 recognises the opportunity that new shopfronts can bring by learning from past mistakes and that good modern design can be an effective advertisement for the quality of the establishment;
- 8.5 draws particular attention to the component parts of good traditional shopfronts when new or replacement shopfronts are built;
- 8.6 considers all end users (e.g. accessibility requirements).

Meets criteria If not, reason for not meeting

<input type="checkbox"/>	<input type="checkbox"/>
<input type="checkbox"/>	<input type="checkbox"/>
<input type="checkbox"/>	<input type="checkbox"/>
<input type="checkbox"/>	<input type="checkbox"/>
<input type="checkbox"/>	<input type="checkbox"/>
<input type="checkbox"/>	<input type="checkbox"/>

8 SHOPFRONTS AND SIGNAGE



Shopfronts in Thame, Oxfordshire



Hanging sign in Thame and shutters in Wallingford (Oxfordshire)

☑ TEST YOUR DESIGN:

Traditional shopfront features

Ensure your proposal considers the following:

- 8.7 the fascia, where the name of the establishment is displayed, should respect the proportions of the rest of the shopfront and the building in which it is set. It should not be too deep, wide or project forward from the face of the building;
- 8.8 pilasters and consoles should be used to support the fascia. They are sometimes decorated and often form an important part of the overall shopfront design;
- 8.9 stallrisers provide a strong visual base to the shop window and can serve as additional security and protection;
- 8.10 shop windows should generally be subdivided to achieve well-proportioned frontages. In some cases glazing bars help to create visual relief, rhythm and an attractive design;
- 8.11 doors are often recessed and have a solid lower panel which at least matches the height of the stallriser;
- 8.12 materials should be in keeping with the character and appearance of the building;
- 8.13 modern 'Dutch' blinds and canopies in plastic or similar materials which do not retract are often obtrusive to the appearance of the building and street scene and unlikely to be acceptable on listed buildings or in conservation areas.
- 8.14 projecting and hanging signs, if they are necessary, should be small and traditional in design of hand-painted hanging signs from wrought iron brackets and carefully positioned so as not to obscure details of the shopfront or other parts of the building.
- 8.15 when considering hanging signs over pavements, make sure they do not cause issues for people with visual impairments.

Meets criteria If not, reason for not meeting

<input type="checkbox"/>	<input type="checkbox"/>
<input type="checkbox"/>	<input type="checkbox"/>
<input type="checkbox"/>	<input type="checkbox"/>
<input type="checkbox"/>	<input type="checkbox"/>
<input type="checkbox"/>	<input type="checkbox"/>
<input type="checkbox"/>	<input type="checkbox"/>
<input type="checkbox"/>	<input type="checkbox"/>
<input type="checkbox"/>	<input type="checkbox"/>
<input type="checkbox"/>	<input type="checkbox"/>

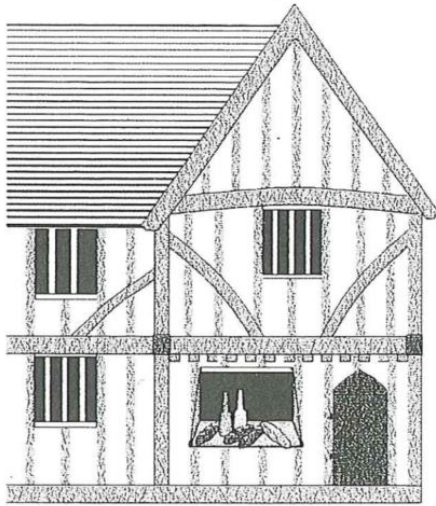

A medieval shopfront



A victorian shopfront

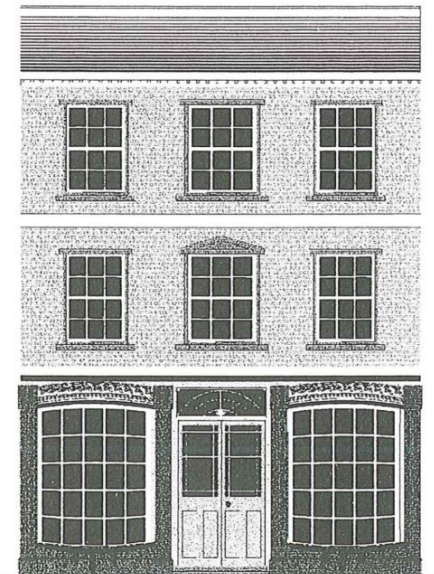

A georgian shopfront

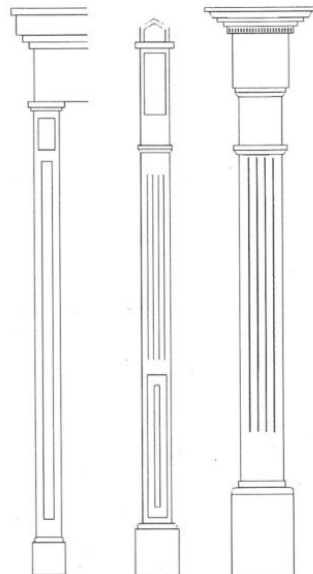

Traditional wooden pilaster designs

TEST YOUR DESIGN:

Traditional shopfront features

Ensure your proposal considers the following:

- 8.16 illumination of fascias and hanging signs is not encouraged in historic town centres. Where exceptions may be made in the cases of public houses, restaurants or similar late-opening premises absolutely necessary, then it should be low key and discreetly positioned.
- 8.17 alterations to historic shopfronts must balance the requirement to preserve historic character with the needs of adequate access;
- 8.18 shopfront security can be very damaging to the character of the building and street. Sympathetic solutions, such as toughened glass, better internal lighting, internal video cameras and alarm systems can often be just as effective without the deadening effect of shutters and grilles.
- 8.19 repair of traditional shopfronts should always be the first option, rather than their wholesale replacement;
- 8.20 the design of shopfronts in modern buildings, although allowing for innovation, should still reflect the basic principles of traditional shopfront design which have stood the test of time. New design should reflect both the character of the building and the street in which it is set.

Meets criteria If not, reason for not meeting

<input type="checkbox"/>	<input type="checkbox"/>
<input type="checkbox"/>	<input type="checkbox"/>
<input type="checkbox"/>	<input type="checkbox"/>
<input type="checkbox"/>	<input type="checkbox"/>
<input type="checkbox"/>	<input type="checkbox"/>

9 NON-DOMESTIC BUILDINGS

HOW TO DESIGN FOR NON-DOMESTIC BUILDINGS

GOAL: Well-designed buildings and spaces which respond to the needs of the users and contribute positively to the built environment

It is well known that the way a building is designed affects the way we feel and respond to it. Better designed buildings and outside spaces will enhance the users experience – this could be staff, visitors or customers for example. There is therefore a direct link between the design of the building and the commercial success of a business using it.

Buildings must be designed appropriately for their function. However, they must also be designed to contribute to an attractive, safe and active environment that is sustainable for the future.

This guide will help establish the key design and planning principles of any new industrial, commercial or retail development to ensure that the buildings and spaces can be as effective and successful as possible and respectful of their setting.



Cuddesdon Chapel, Cuddesdon

+ Additional useful and interesting resources:

- The value of urban design (CABE and DETR, 2001) and the value of good design (CABE, 2002)
- BS8300: 2009 Design of buildings and their approaches to meet the needs of disabled people. Code of practice (2009)



To inform your design:

Technical studies including (but not limited to) surveys on trees, habitats, species etc. where appropriate



To communicate your design:

- Clear elevations, roof plans, floor plans
- A block plan and/ or landscape plan with a clear legend
- Three dimensional models
- Sunlight/ daylight diagram



Entrance court of award-winning Ercol building in Princes Risborough



A range of non-domestic buildings (Milton Park and community centre in Didcot)

TEST YOUR DESIGN:

Layout

The development must:

- 9.1 have buildings located on the edge of the site to enclose and overlook public streets, car parking and open spaces to create a strong urban form and active frontages;
- 9.2 have main entrances that face onto the street, are easily visible and accessible and provide protection from wind and rain;
- 9.3 keep on-site parking to a minimum to help achieve a sustainable development. Provide or link into good pedestrian and cycle links;
- 9.4 include substantial elements of planting and a quality landscaping scheme within the space and on the boundaries;
- 9.5 locate parking and service yards to the rear screened by buildings and landscaping enclosure;
- 9.6 not have an excess of lighting columns, bollards or street clutter;
- 9.7 boundaries that reflect the character and appearance of the area and proposed new building.
- 9.8 provide 6% accessible parking bays.

Meets criteria If not, reason for not meeting



Rowing Museum, Henley (Oxfordshire)

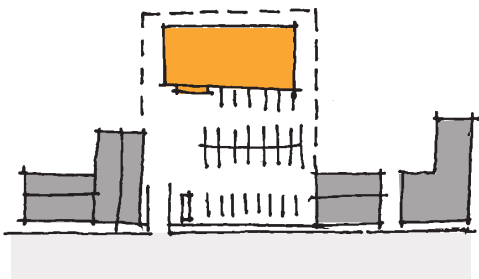

Bad example of commercial parking arrangement



Good example of commercial parking arrangement

TEST YOUR DESIGN:

Car parks

The development must:

- 9.21 subdivide large spaces dedicated to car parking into a number of well-defined areas which relate to the buildings that they serve;
- 9.22 screen service areas and large areas of parking and minimise the car park frontage onto public streets;
- 9.23 incorporate landscaping that responds to and enhances the local environment.

Meets criteria If not, reason for not meeting

HOW TO DESIGN APARTMENTS

GOAL: To make sure that apartments respond in a contextual and sensitive way to their setting

Apartments, also known as flats are sustainable forms of development because they increase housing density and therefore reduce the pressure for development on greenfield land. They also provide a wider choice of dwelling size and type, meeting the needs of more residents.

Their design can also be a challenge to achieve a visually interesting and functional building that respects the character and appearance of the local area. Their scale, height and massing along with the requirements for parking, bin storage and private amenity space means that clear guidance on well-established design principles is required to ensure that the proposed buildings can be as successful as they can be.



Newbuilt apartments with good natural surveillance, Mariners Quay, Newport



Additional useful and interesting resources:

- Technical documents of this guide
- Urban design lessons: Housing layout and neighbourhood quality (HCA, 2014)



To inform your design:

Technical studies including (but not limited to) surveys on trees, habitats, species etc. where appropriate



To communicate your design:

- Clear elevations, roof plans, floor plans
- A block plan and/ or landscape plan with a clear legend
- Three dimensional models
- Sunlight/ daylight diagram



Newbuilt apartments with visual interest and overlooking open space (Accordia, Cambridge)



Apartments in a converted building, Henley



Newbuilt apartments that run the corner (Winchester)

TEST YOUR DESIGN:

Apartment buildings must:

- 10.1 have access to outdoor amenity space. This can be provided in the form of private gardens for ground floor flats, balconies, roof gardens or terraces, or private shared gardens;
- 10.2 be broken down into a series of components to reduce their perceived bulk and massing where large footprint buildings are needed;
- 10.3 respect their surrounding context in terms of scale and height. In some instances, taller buildings could be used as an opportunity to create landmark buildings;
- 10.4 have secure and convenient cycle storage provided within the main buildings and preferably close to main entrances;
- 10.5 have dedicated visitor cycle parking provided close to main entrances and well overlooked by habitable rooms;
- 10.6 locate main entrances directly facing onto the street and be clearly visible from the public realm. All building entrances should be welcoming and easily identifiable to help improve legibility;
- 10.7 provide individual entrances for ground floor dwellings where they front the street and generous sized entrance cores, well lit by natural light and naturally ventilated;
- 10.8 incorporate individual letterboxes, cycle storage and access to refuse areas;
- 10.9 keep the number of dwellings accessed from a single core (should be between 2 - 8 per floor to increase social interaction with neighbours and increase residents sense of ownership);
- 10.10 include residents, accessible parking bays and visitor parking that is well overlooked and integrated into the landscaping strategy for the site. Parking must not visually dominate the setting of the buildings.

Meets criteria If not, reason for not meeting

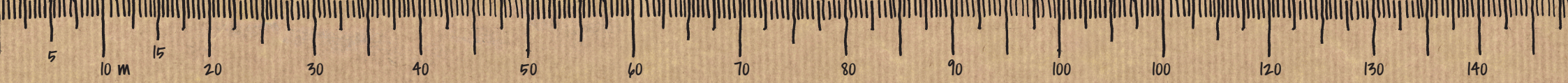

1:500

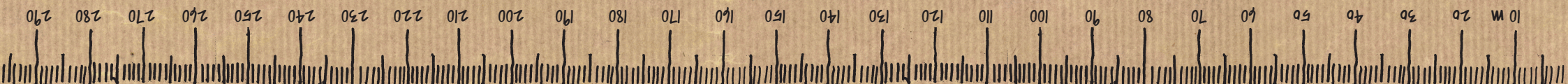
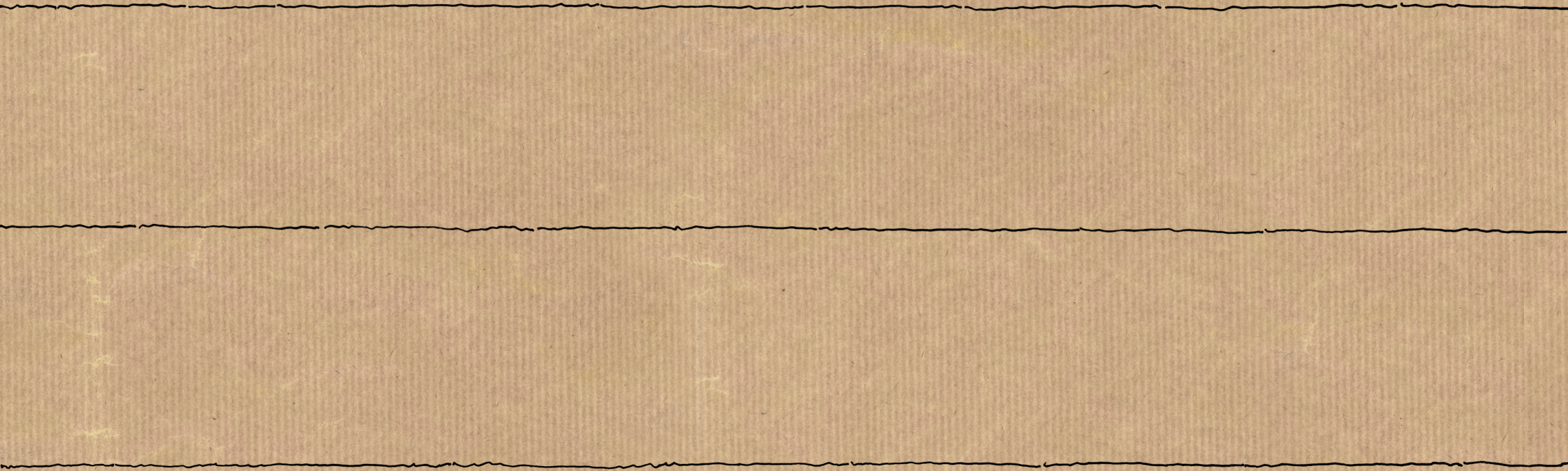

1:1000